

Mini II MSC Safety Cabinet

Effective, economical, protection for operator and process



Mini II MSC is a small width Safety Cabinet ideal for use by one operator and for the energy conscious, space limited laboratory.

FEATURES

- Quiet operation
- Energy efficient fan/low running costs
- Energy saving LED lighting (option)

DESCRIPTION

In-flow air enters the front to establish operator protection, down flow sterile air protects the enclosed samples and equipment. Room air does not enter the work zone which prevents sample/process contamination.

The user is provided with detailed system status on a 3.2" TFT touch screen controller and display.

Bigneat's Mini II MSC Safety Cabinet is manufactured to a very high standards using only the best quality materials. The mild steel body is finished in a white epoxy protective coating. The front window and front closure panel (night door) are manufactured from 8mm thick clear cast acrylic and the internal work surface is 316L stainless steel. Double hinges and vice action 'T' latch handles facilitate easy access to cabinet interior for cleaning and loading.

TFT TOUCH SCREEN CONTROLLER

The inflow air is maintained at 0.4m/s or greater and down flow air between 0.25m/s and 0.5m/s. The balance is precisely measured and controlled, audible air flow failure alarm.

MINI II MSC OPTIONS

Flexible entry access designed to best fit your process:

- Acrylic or glass front window and/or side panels.
- Interlocked side-mounted transfer port.

Internal removable stainless steel worktop, flat full-width, is provided as standard.

Easy cleaning and accidental spill removal options:

- Two section, half width
- Three section, third width
- Profiled for spillage collection

A heated version is available for Tissue Culture and IVF applications.

OPTIONS AND EXTRAS

- Formalin vaporiser sterilization unit
- Upgrade of HEPA filtration to ULPA
- Internal free-standing UV sterilization unit
- Splash-proof electrical sockets
- Gas, nitrogen and vacuum services
- Drainage to lower sump for liquids/spillages
- Internal stainless steel corner shelves

SUPPORT BENCH, MOBILE OR STATIC

Mount your Mini II MSC on an existing bench or have a free standing system. Select an open robust epoxy coated bench with castors or one with levelling/adjustable feet. An electrical motorised height adjustable version is available on request.

Height to work surface: 860mm



Compare Bigneat's Mini II MSC running costs with similar width cabinet and consider the annual savings to be made. Power consumption is only 183W including lighting (Model M2800) and 358W (Model M2120).

TECHNICAL INFORMATION

Model	Description	Dimensions (External WxDxH)	Dimensions (Internal WxDxH)
M2800R 850mm wide	Mini II MSC R recirculatory filtration, supplied complete with lighting, single HEPA filter (H14 grade).	854 x 650 x 1216 mm	814 x 418 x 686mm
M2120R 1200mm wide		1200 x 650 x 1216 mm	1160 x 418 x 686mm
M2800D 850mm wide	Mini II MSC D supplied complete with lighting, single HEPA filter (H14 grade), and exhaust spigot for ducted installation.	854 x 650 x 1216 mm	814 x 418 x 686mm
M2120D 1200mm wide		1200 x 650 x 1216 mm	1160 x 418 x 686mm
M2800R2 850mm wide	Mini II MSC R2 recirculatory filtration system supplied complete with lighting, two HEPA filters (H14 grade) with exhaust filter box.	854 x 650 x 1466 mm	814 x 418 x 686mm
M2120R2 1200mm wide		1200 x 650 x 1466 mm	1160 x 418 x 686mm

Mini II MSC is available for power supply: 230V, AC, 50Hz, 5Amp, 1Ø or 110V, AC, 60Hz, 8Amp, 1Ø.

▶ DIAGRAMS

Model M2120 – 1200mm wide shown

Engineering drawings available on request.

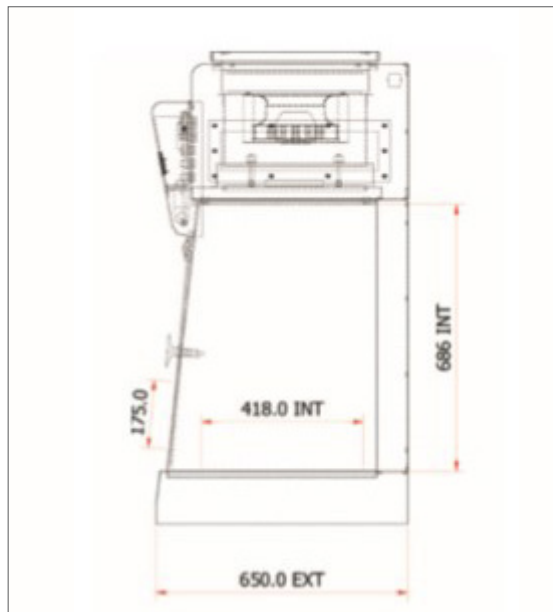
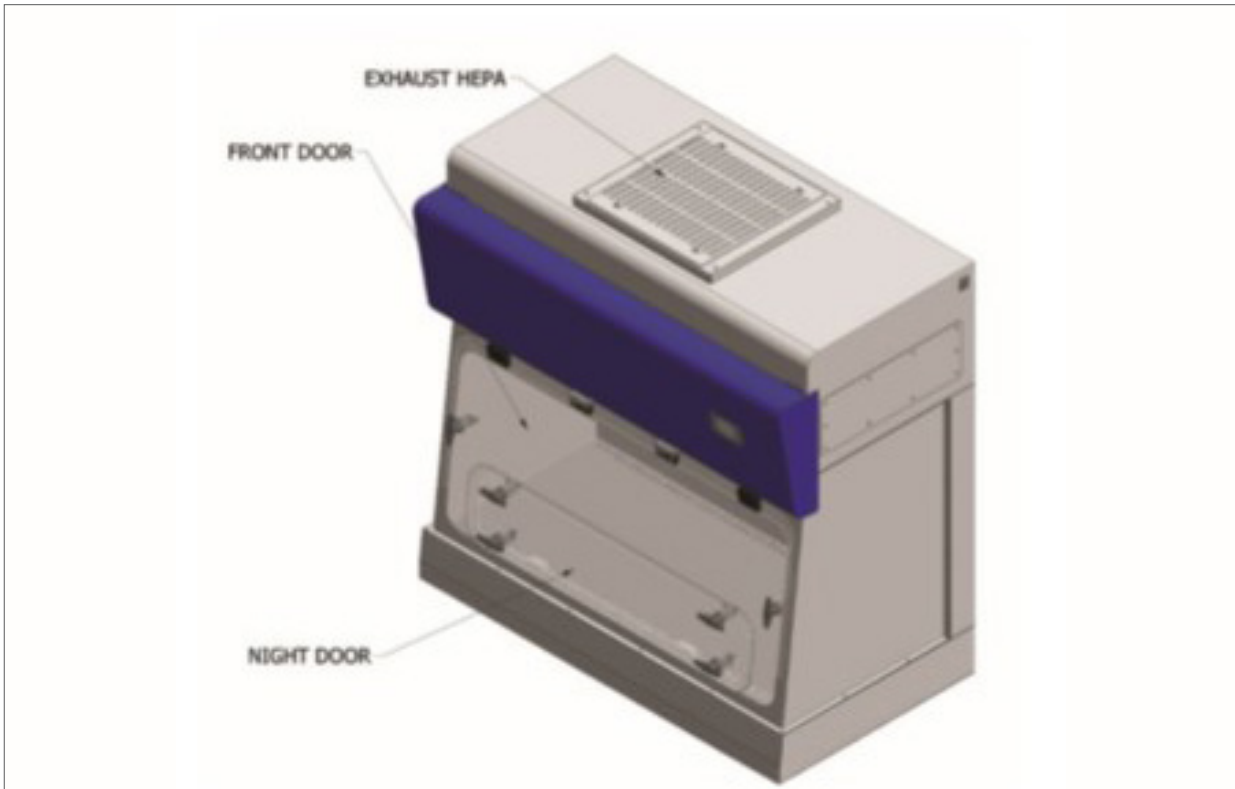

▶ QUALITY ASSURED



Bigneat is accredited to
BS EN ISO 9001: 2008



Bigneat systems
are CE marked

Bigneat manufactures from UL approved components

Bigneat Limited

4 & 5 Piper's Wood Industrial Park, Waterberry Drive, Waterlooville, Hampshire PO7 7XU UK

t: +44 (0)23 92 266400 f: +44 (0)23 92 263373 e: info@bigneat.com w: www.bigneat.com

